

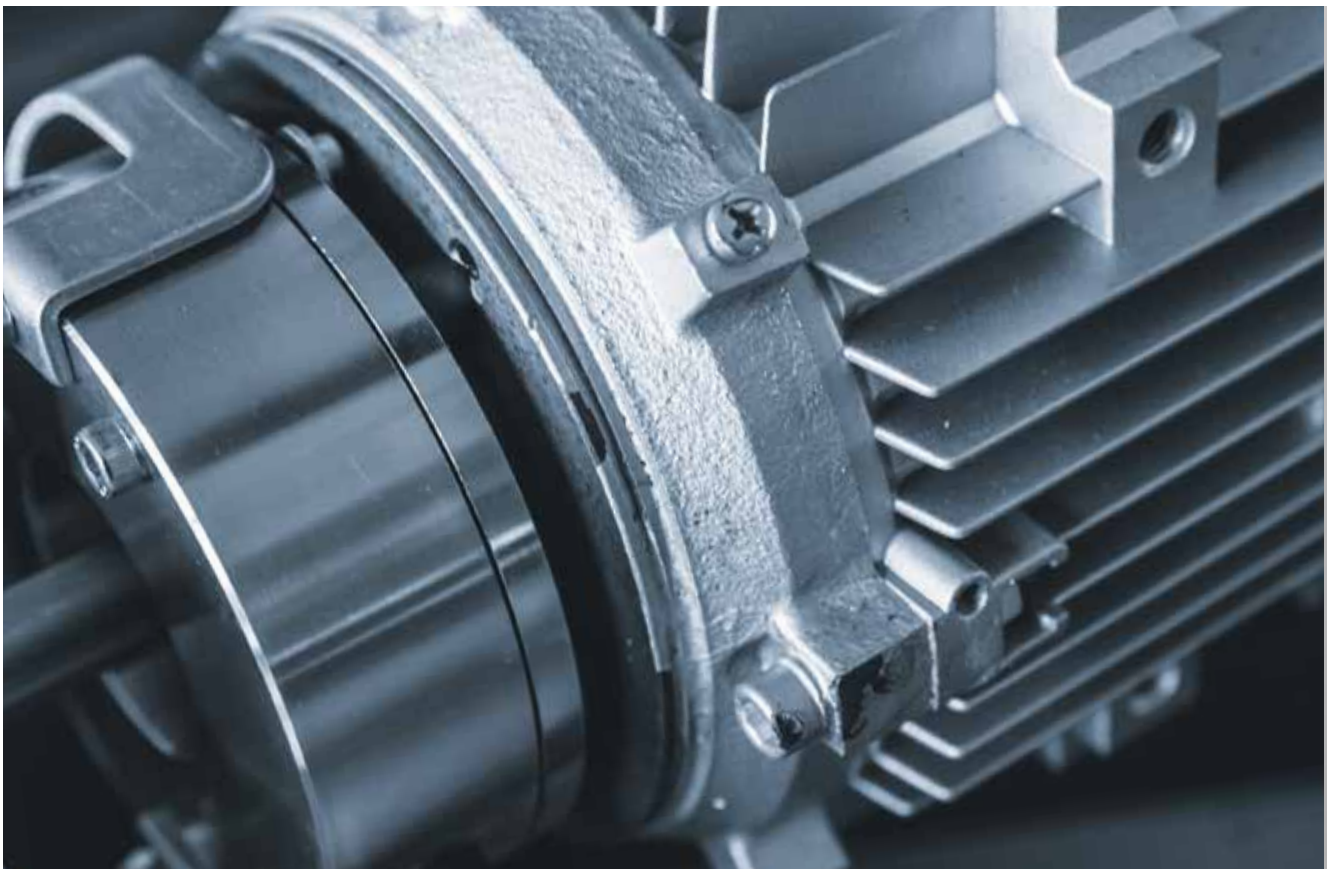

**BENSHAW**  
*Applied Motor Controls*

WHITE PAPER



# Get Your Motor Running: Motor Starting Solutions

*Rapid | Rugged | Global*

# Get your motor running

***The starting function of motors is often misunderstood, impacting motor performance and compromising energy efficiency.***

It is often believed that the start current of a motor under full voltage conditions depends on the driven load, but this is totally incorrect. In this paper we discuss the relationship between motor design, load and start current, and examine the basics of a range of fixed-speed motor starting technologies.

## Motor starting

There are many misconceptions about motor starting. It is often believed that the start current of a motor under full voltage conditions depends on the driven load, but this is totally incorrect.

The start current of the motor depends on the motor design, rotor speed and stator voltage from zero speed until full speed is reached. The load only influences the time taken for the motor to reach full speed. The current/speed curve of the motor is independent of all external influences other than stator voltage.

The motor will always initially draw locked rotor current (LRC) when started direct-on-line (DOL). The current will stay at LRC as the motor begins to accelerate, and fall as the motor approaches full speed.

For many induction motors the current does not fall significantly until the motor speed is over 90%.

Starting an unloaded motor DOL is just as severe on the supply as starting a fully loaded motor, except that the overload is for a shorter time. Note: Some clamp type ammeters with slow response times do not show the true start current.

## FULL VOLTAGE STARTING: DOL STARTERS

The simplest form of motor starter is the full voltage direct-on-line (DOL) or across-the-line starter, consisting of an isolation contactor and motor overload protection device. In some industries DOL starters are used extensively. However in many situations full voltage starting is not permitted by the power authority due to the high starting currents and the voltage disturbances they cause.

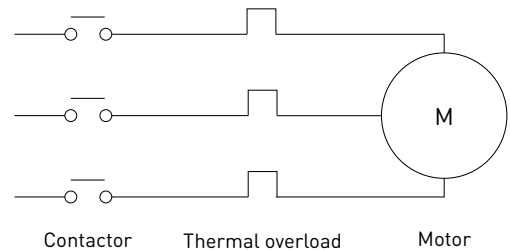

The DOL starter causes a current transition from zero to LRC at the instant of contactor closure. This current typically ranges from 600% to 900% FLC. The result is a voltage transient induced in the supply by the fast rising current transient, and a voltage deflection of six to nine times that expected under full load conditions.

Full voltage starting also causes a torque transient from zero to locked rotor torque (LRT) at the instant of contactor closure.

The instantaneous torque application results in a severe mechanical shock to the motor drive system and the machine. The damage from the torque transient is more severe than the damage from the maximum torque amplitude.

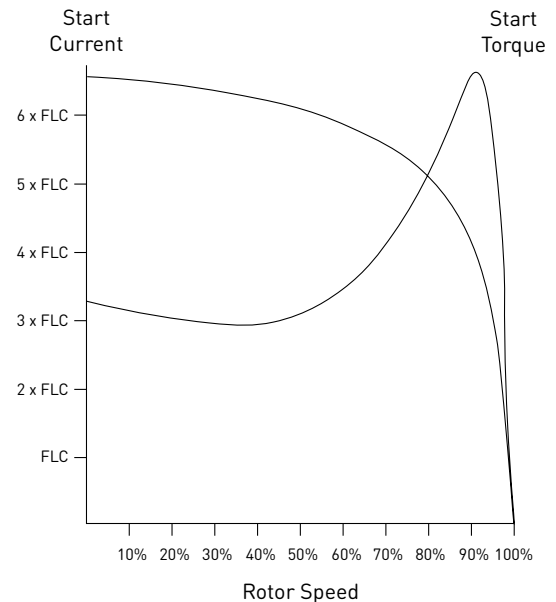

## REDUCED VOLTAGE STARTING

***Full voltage starting of induction motors results in maximum start torque, maximum start current and minimum start time. Electromechanical reduced voltage starting reduces start current and start torque, and increases start time.***

Three traditional methods of reduced voltage starting are commonly used:

- Primary resistance starting
- Auto-transformer starting
- Wye-delta starting

Reduced voltage starting is used extensively and in many areas is mandatory. The use of reduced voltage starting has been promoted as a means of reducing power supply voltage disturbances resulting from motor starting.

In reality the benefits are marginal due to the misapplication of reduced voltage starters. Many installations would suffer fewer disturbances if a full voltage starter replaced the poorly applied reduced voltage starting system.

The reduced voltage starter must be able to accelerate the motor to almost full speed before stepping to full voltage. A step to full voltage at much less than rated motor speed will result in a current step that can be very close to LRC.

Switching to full voltage at 80% speed results in a current of typically 75% LRC, or 500% FLA. At 50% speed, the current would be 90% LRC. The maximum current will be significantly reduced only if the changeover occurs at a rotor speed of 90% or more.

The speed of the motor at changeover depends on the torque of the motor at the reduced voltage, and the speed/torque curve of the load. If the time in the reduced voltage is too short, the motor may not have time to accelerate to the speed where the available torque equals the load torque, resulting in a premature transition to full voltage.

The two controllable parameters which determine the reduced voltage starter's performance are therefore start time and start voltage. If either of these parameters is not correctly set, then the reduced voltage starter is of limited advantage.

The transition from the reduced voltage to full voltage can be open transition switching or closed transition switching.

Open transition switching occurs when the starter goes through an open circuit stage in the switching sequence. There are three stages:

1. Connect to the reduced voltage
2. Disconnect from the reduced voltage (open circuit)
3. Connect to the full voltage

Open transition starting causes severe current and torque transients which can be far more detrimental to the supply and the mechanical equipment than full voltage starting. When the motor is spinning and then disconnected from the supply, it acts as a generator with an output voltage which may be the same amplitude as the supply.

The frequency of the voltage generated by the motor depends on the motor speed. The voltage generated by the motor during the open transition decays to zero slowly and at the time of reclose there can still be significant voltage present at the motor terminals. As the frequency of the voltage generated by the motor will always be less than the supply frequency there will invariably be an instantaneous voltage difference between the motor terminals and the supply.

The voltage generated by the motor at the instant of reclose may be equal to the supply voltage but exactly out of phase. This equates to reclosing with twice the supply voltage on the motor. The result is a current transient of 200% LRC and a torque transient of 400% LRT. The transients associated with open transition starters are responsible for many of the supply disturbances and mechanical breakdowns experienced in industry.

The closed transition starter does not have an open circuit step in changing from the reduced voltage to the full voltage. During the transition period the starter provides bridging impedance between the supply and motor to eliminate the open circuit.

## PRIMARY RESISTANCE STARTERS

The primary resistance starter is one step beyond the DOL starter. Resistors are connected in series with each phase, between the isolation contactor and the motor. The resistors limit the start current and torque.

The motor current is equal to the line current and the starting torque is reduced by the square of the current reduction ratio. The current reduction depends on the ratio of the motor impedance to the sum of the added primary resistance and motor impedance.

As the motor accelerates, the stator impedance increases, resulting in increasing stator voltage with speed. Once the motor is up to full speed, the resistors are bridged by a second contactor to supply full voltage to the motor. The initial start voltage is determined by the value of the resistors used. If the resistors are too high in value, there will be insufficient torque to accelerate the motor to full speed. In this case, the step to full voltage will result in a high current and high torque step.

The reduced voltage start time is controlled by a preset timer which must be correctly set for the application. If the time is too short, the motor will not have achieved full speed before the resistors are bridged. If the time is too long, the excessive start time results in unnecessary motor and resistor heating. Several stages of resistance can be used and bridged in steps to control the current and torque more accurately, and so minimize the magnitude of the current and torque steps.

Primary resistance starters dissipate a lot of energy during start due to the high current through the resistors, and the high voltage across the resistors. The resistors may be wound, cast or liquid resistors. For extended times or frequent starts, the resistors are physically large and must be well ventilated.

Primary resistance starters are closed transition starters, so they are not subject to reclose transients.

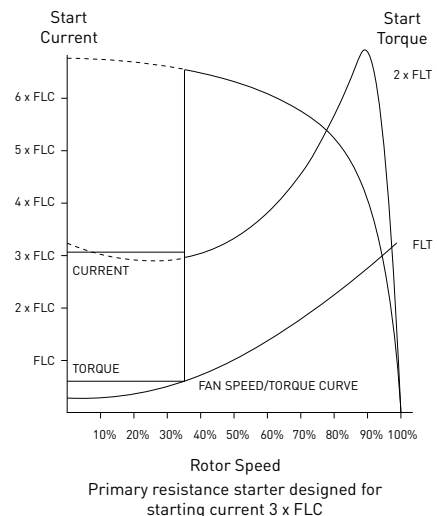
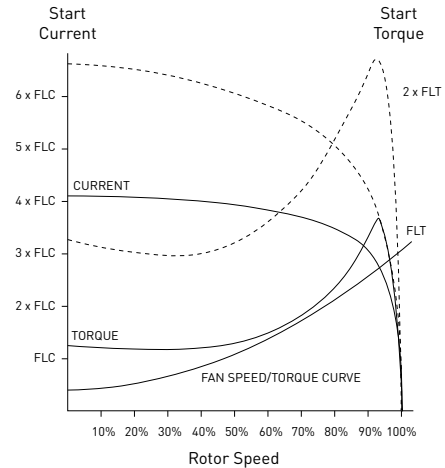
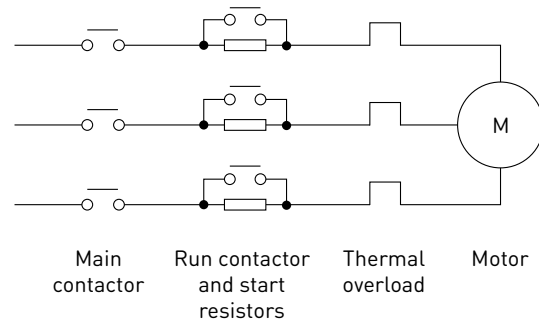

## AUTO-TRANSFORMER STARTERS

The auto-transformer starter uses an auto-transformer to reduce the voltage during the start period.

The transformer has a range of output voltage taps which can be used to set the start voltage.

The motor current is reduced by the start voltage reduction, and further reduced by the transformer action resulting in a line current less than the actual motor current. The initial line current is equal to the LRC reduced by the square of the voltage reduction.

A motor started on the 50% tap of an auto-transformer will have a line start current of 25% LRC and a start torque of 25% LRT.

During the motor acceleration period, the starter may be designed to step through two or more voltage steps from the initial start tap to full voltage. The simplest auto-transformer starters are single step and often control only two phases. The initial start voltage is set by tap selection, and the start time is controlled by one or more timers.

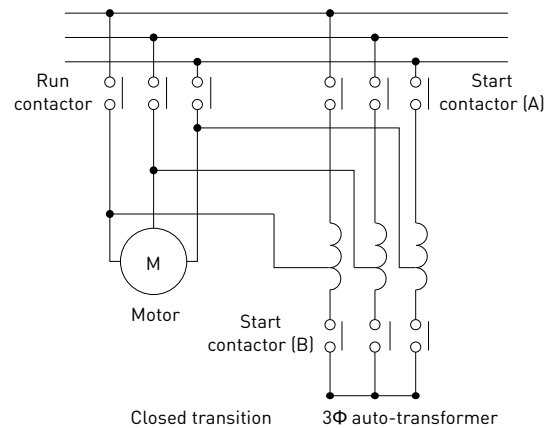
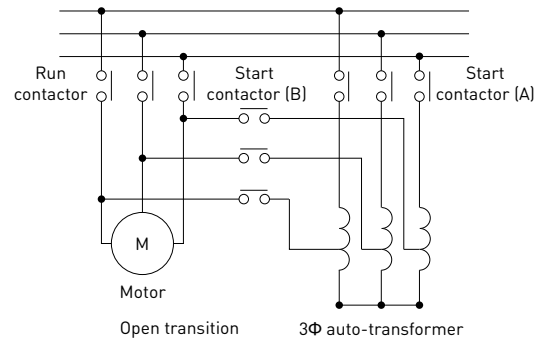



If the start voltage is too low, or the start time incorrectly set, the transition to full voltage will occur with the motor at less than full speed, resulting in a high current and high torque step.

Auto-transformer starters are usually rated for infrequent starting duties. Frequent or extended start rated auto-transformers are large and expensive due to the heating in the transformer.

Auto-transformer starters can be constructed as open transition starters but usually the Korndorfer closed transition configuration is used to eliminate the reclose transients.

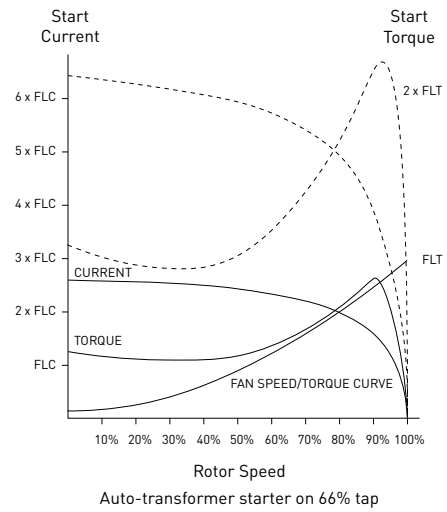
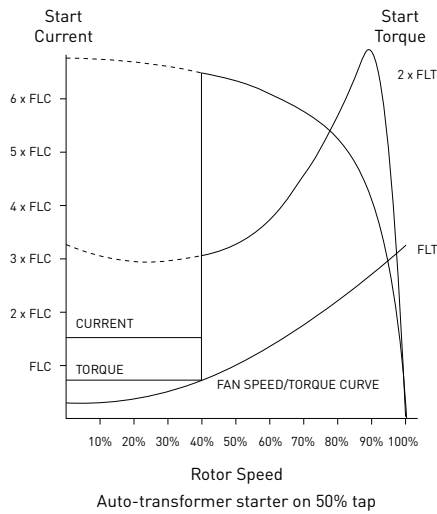

## WYE-DELTA STARTERS

The wye-delta starter is the most common reduced voltage starter used in industry because of its low cost. The wye-delta starter has traditionally met the requirement for reduced voltage starting, but in many installations the advantage of its use is questionable.

The motor is initially connected in wye configuration and then after a preset time the motor is disconnected from the supply and reconnected in delta configuration.

The current and torque in the wye configuration are one third of the full voltage current and torque when the motor is connected in delta. The current and torque for any one motor cannot be controlled to suit the application. Only two possible choices are available, wye or delta configuration.

If there is insufficient torque available in wye configuration to accelerate the load to full speed, a high starting torque motor such as a double cage motor should be used. If the motor does not reach full speed in wye, the transition from wye to delta configuration will result in a high current and high torque step, defeating the purpose of reduced voltage starting.

Most wye-delta starters are open transition starters so the transition from wye to delta results in very high current and torque transients in addition to the high step magnitudes. Closed transition wye-delta starters are rarely used due to their increased complexity and cost. The closed transition starter reduces the reclose effect but does not improve the controllability of the start parameters.

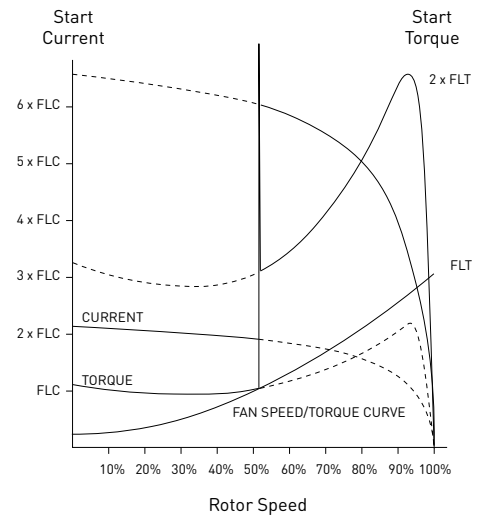
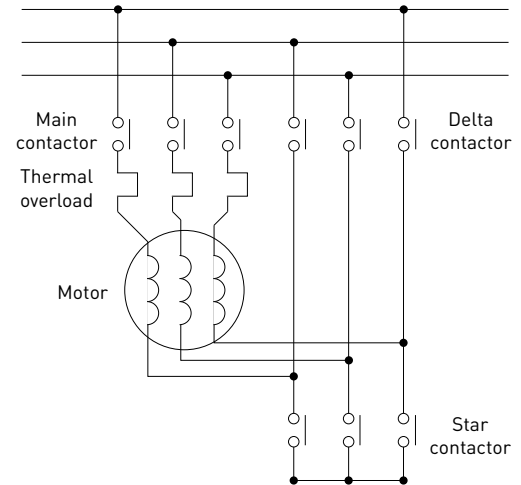

## SOLID STATE SOFT STARTERS

The solid state soft starter is similar to the primary resistance starter in that it controls the voltage applied to the motor by means of impedance in series with each phase connected to the motor.

The solid state soft starter uses solid state AC switches instead of fixed or liquid resistors. The AC switches are triacs, reverse parallel connected SCR-diode, or SCR-SCR circuits. The voltage is controlled by variation of the conduction angle of the SCRs or triacs.

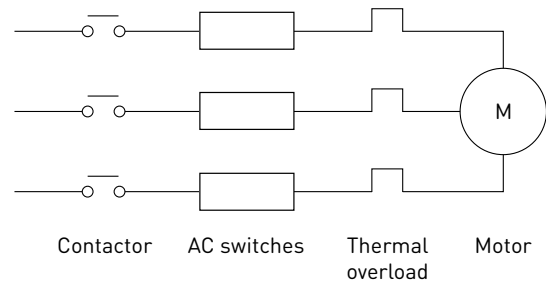

Solid state soft starters are both symmetric controllers resulting in odd order harmonic generation. The asymmetric control of the SCR-diode AC switch causes even order harmonic currents to flow in the motor and supply. The even harmonics are undesirable for motor control because of the increased losses and heating induced in the motor and supply transformers. Therefore, SCR-diode designs are rarely offered.

The AC switch has a very low power dissipation compared to traditional primary resistors and is controllable to give a motor voltage from zero to full line voltage without any steps or transients.

Solid state soft starters come in two control formats:

- Open loop control
- Closed loop control

Open loop controllers, like traditional electromechanical starters, operate following a preset timed sequence. The most common open loop system is the timed voltage ramp where the voltage begins initially at a preset start voltage and increases to line voltage at a preset ramp rate.

Closed loop controllers monitor one or more parameters during the start period and modify the motor voltage to control the starting characteristics.

Common closed loop controllers are:

- Constant current
- Current ramp
- Constant acceleration

Solid state soft starters can be designed to give greater starting duties than most motors, and because of their linear voltage control do not cause current or torque steps or transients. Solid state soft starters are transition-less.

## Summary

It is possible to correctly apply and engineer electromechanical reduced voltage starters so the torque and current magnitudes and transients are reduced to acceptable levels. However the mis-application of motors and starters often results in voltage flicker and deflections well in excess of those experienced with DOL starting techniques.

Incorrectly installed and poorly calibrated electromechanical starters eventually reach full voltage and DOL start the motor, acting as expensive DOL starters.

Reduced voltage starting is specified in order to reduce the electrical interference caused by motor starting. It is also used in many applications to reduce the mechanical damage caused by torque transients and steps. To achieve these objectives the motor and starter must be correctly selected and commissioned for optimum performance.

## **Benshaw Group**

### **Benshaw, Inc.**

615 Alpha Drive  
Pittsburgh, PA 15238 United States  
Toll Free: 1-800-441-8235  
Phone: 412-968-0100  
Fax: 412-968-5415

### **Benshaw Canada Controls, Inc.**

550 Bright Street East  
Listowel, Ontario N4W 3W3 Canada  
Toll Free: 1-877-291-5112  
Phone: 519-291-5112  
Fax: 519-291-2595

### **Benshaw Excel**

Detroit, MI

### **Benshaw - Aucom Ltd.**

New Zealand

### **Benshaw - Aucom Ltd. International**

- Germany
- Dubai
- Korea

[www.Benshaw.com](http://www.Benshaw.com)



**BENSHAW**  
*Applied Motor Controls*